



Companion Mini

Connect

HANDBOOK



LESS STRESS CARING

Your product has been manufactured by a team of industry experts with more than 20 years of experience designing, manufacturing and distributing care alarms.

With a commitment to quality and innovation we are able to bring you a robust and reliable system to aid carers and the safeguarding of individuals. Please read this quick start guide carefully to ensure the correct set up, use, and maintenance of your new product for years to come.

If you have any questions or require assistance in regards to the Companion mini, Connect-iT or any other Alert-iT product, our experienced team are on hand to help. Please find contact details below. Don't forget you can also join us on Facebook, Twitter and LinkedIn where you'll find even more information and advice.



Head Office: Sales@alert-it.co.uk

Call: 01530 239 900

Social:

 AlertitCareAlarms

 Alert_iT_Care

 Alert-iT

Product Information	5
In The Box	6
Quickstart	7
Using the device with a 3rd party radio module	7
Companion mini Function	10
Device Installation	10
Turning on the Companion ^{mini} (Monitor)	10
Positioning and Setup	11
System Operation	12
Maintenance Instructions for the mini	14
Connect-iT Function	15
Turning the Connect-iT on	
Pairing	
Clearing the Memory	
Function	16
Front panel Lights	
Wired Output	
Resetting an Alarm (Excluding the Companion mini)	
Common Fault Conditions	
Alarm Conditions	17
Normal Alarms	
Mounting the unit to a wall	
Removing the Connect-iT from Service	

Contents

4

Installation	18
Nurse Call Cables/Leads	19
Leads available from Alert-iT	
Wired Output Specification	
Advanced Options	20
Maintenance Instructions for Connect-iT	21
Routine Testing of the Backup Battery	
How to Clean the Device	
Additional Info	22
Third Party Radio Transmitters	22
Troubleshooting	23
Warranty Information	24
Companion mini Specification	25
Certification	25
Connect-iT Specification	26
Certification	26
Routine Test Sheet	27
Profiler Editor Software	29
Product Information	31

This product has been designed to discreetly monitor the user with high performance sensors which detects prolonged movements that could indicate a seizure.

The Companion mini is paired to the Connect-iT via Alert-iT's failsafe "**Safelink**[®]" radio system. Upon detection of an alarm condition the Companion mini alerts the Connect-iT, which in turn triggers a nurse call point or internally fitted 3rd party radio board.

The Connect-iT will normally be powered from a mains adapter, but it features a battery backup that provides over 24 hours of power in case of a power cut.

The Companion mini is a battery powered device with a 1 year battery life.

The Companion Mini Pack Contains:		
A	1 x Companion Mini - P176A (C0)	Includes 2 x AAA Non-rechargeable Batteries
B	1 x Foam Block	
C	1 x Companion Mini Mounting Kit	
D	1 x Connect-iT - P155B MKII	Includes 2 x AA Ni-MH Rechargeable Batteries
E	1 x 12v Power Supply - P171	
F	1 x Wall Mounting Kit (Not Shown)	2 x Wall screws + Wall plugs / 2 x Sticky pads



PLEASE NOTE:
Nurse Call Leads are not included and are provided separately. See page 19 for further details.

- ✓ Unpack box
- ✓ Turn on the Companion mini by pressing the recessed “**Test**” button with a pen tip
- ✓ Place the mini under the bed
- ✓ Press the “**Pair**” button on the Connect-iT to turn it on
- ✓ Plug the P171 Power Supply into a mains socket, then plug the other end into the socket labelled “**12v DC**”. (The green “**Power**” LED should turn on)



Figure 1

Using the device with a nurse call point

- ✓ Plug the red end of the nurse call cable into the socket labelled “**Output**”
- ✓ Plug the other end of the nurse call cable into the nurse call point



Figure 2

Using the device with a 3rd party radio module

- ✓ Pair the Connect-iT with the 3rd party pager as described in their manual. See page 22 for more details

- ✔ Now ensure that the “**Monitor**” LED flashes green every time the radio product transmits (Every 8 seconds for a Safelink enabled product like the Companion mini)
- ✔ Ensure the “**Alarm**” LED flashes and the Wired output activates when the monitor is triggered. See page 16 for details
- ✔ Pull out the 12v DC jack to simulate a power cut. The device should continue to operate as expected on the battery backup. See page 16 for details of LED status
- ✔ Fix the Connect-iT’s back panel to a wall using the provided screws OR sticky pads
PLEASE NOTE:
We highly recommend screws are used, as the sticky pads can slowly work their way loose over time unless the surface is perfectly clean and flat
- ✔ Clip the Connect-iT onto the back panel
- ✔ Route the cables to ensure they do not pose an entanglement or trip hazard
- ✔ You can now return the monitors to their intended locations and test the system works as expected. i.e Monitors are within range of each other and trigger your system/nurse call



Figure 3

Using the device with a 3rd party radio module

- ✔ As you are paired with a Safelink enabled monitor, the Connect-iT will raise a **“Radio Fail”** fault and trigger an alarm if it does not receive any radio signals for 2 minutes.
- ✔ So if the wired output is activating unexpectedly and the **“Monitor”** LED is flashing it may be that the monitor has been turned off.
- ✔ The lights and sounds can be disabled by holding the **“Clear”** button on power-up. See page 20 for details.
- ✔ Please be aware that Nurse Call systems which do not use a **“Normally closed”** connection may not be alerted if the nurse call lead is unplugged or disconnected. Regular testing must be performed to ensure system is working as intended.
- ✔ It is recommended not to use this system where a risk is identified that users are likely to intentionally remove cables, or intentionally un-pair / tamper with the monitors, as alarm conditions may not be annunciated at the carers location.
- ✔ Use rechargeable batteries (listed) only!

Device Installation

Turning on the Companionmini (Monitor)

The Companion mini monitor is shipped in a low-power state.

The monitor is turned on by pressing the recessed '**Test**' button on the front of the monitor (Figure 1), typically using a pen tip. The monitor will first enter a 60 second test mode.

When the "**Test**" button is pressed the internal green light will flash to indicate the unit is now turned on and in test mode. After 60 seconds the light will stop flashing and the test mode will end.

This test mode exists to allow the user to easily test the positioning of the monitor under the bed. While in test mode, every time the monitor detects movement, it sends out a radio signal to the Connect-iT.



Figure 4

Positioning and Setup

Press and release the “**Test**” button on the front of the monitor to enter the 60 second test mode.

Temporarily place the monitor under the mattress without any fixings.

The monitor performs best if placed beneath the user. However, due to the wide variety of bed types and mattresses, it is advisable to test the units positioning before securing it into place.

If movement isn't detected due to the mattress thickness or density, the foam provide is designed to enhance the sensitivity.

This is used to enhance the sensitivity of the 3 settings available if you require the Companion Mini to detect small tremors associated with the seizure. Please use the sticky pads provided and secure the foam block to the bottom of the Companion mini, place the unit under the mattress in a central location and test by simulating the seizure.

For an example of the seizure presentations discussed above, please see a video which was recorded in a clinical simulation on our YouTube Channel “**Alert iT Care Alarms**”.



Figure 5



Figure 6

If required, the base can be screwed to the bed through the holes in the base (screws not provided) if foam not required.

If a suitable position (place to detect movements) cannot be found, the sensitivity may need to be increased slightly by connecting the monitor (mini) to a PC and making adjustments with the software provided Online <https://alert-it.co.uk/support>

Contact Alert-iT customer support for more information.

As default the monitor detects any excessive movements in the bed for a period greater than 15 seconds.

This 15 second Time Delay is programmable using the provided software.

Please refer to page 16 for how to use this software

System Operation

You should now have the monitor installed in the bed, and the Connect-iT turned on and receiving the Safelink® signal every 8 seconds. Indicated by the red **“Monitor”** LED flashing on the Connect-iT flashing every 8 seconds.

If the Connect-iT stops receiving the failsafe radio signal from the monitor, the **“Alarm”** LED will be permanently lit, the **“Monitor”** LED will flash every 2 seconds and an intermittent alarm tone will sound.

If the monitor’s battery gets low the Connect-iT’s **“Monitor”** LED will flash red every second, to indicate that you should now change the battery in the monitor. (see page 14). When the battery gets very low the **“Alarm”** led will begin to flash and an alarm will activate.

If the monitor now detects any excessive movements in the bed for a period greater than 15 seconds the monitor will enter its alarm mode.

(This 15 second Time Period is programmable using the provided software, contact Alert-iT for support).

Alarm Mode

When prolonged movements are detected, the **“Alarm”** LED on the Connect-iT will light up and the Wired output will activate (Or the internal 3rd party radio transmitter will trigger).

A minute after the spasm activity has ceased, the Companion mini will send an **“All Clear”** signal to the Connect-iT.

SAFETY NOTICE:

The monitor is set to send an alarm signal continuously (every 10 seconds) while spasm activity continues. The monitor will send an **“All clear”** signal, when atleast 1 minute has passed spasm free.

Always check the user even if the alarm appears to have cleared.

Opening Unit in Situ

If the unit has been mounted to a flat surface using screws, remove the top by inserting the tip of a flat-headed screwdriver into the slot next to the USB connector, applying gentle pressure and twisting. See figures 7 & 8.



Figure 7



Figure 8

Routine Testing

It is recommended to test the system weekly by simulating spasm movements on the bed for 15 seconds (the default time unless changed by a user via programming) & ensure the Connect-iT is triggered by observing the red “**Alarm**” LED on the Connect-iT and the activation of any connected 3rd party radio or wired system.

How to Clean the Devices

It is also recommended to regularly clean the units by wiping with cotton wool pads moistened (compressed until dripping stops) with a mild detergent (0.5% washing up liquid) solution or by using an alcohol or baby wipe. Avoid getting any liquid into the micro-USB connector.

Changing Battery's in the Companion^{mini}

Remove the base of the monitor as shown on page 13. Also please notice the polarity marked into the case (Figure. 9) when replacing the 2x AAA batteries.

After changing the battery's, the monitor **MUST** be turned on again by pressing the recessed **TEST** button and waiting for the 60 second test mode to finish.



Figure 9



Figure 10

Turning the Connect-iT on

The Connect-iT is shipped in a low power state to stop the batteries draining during shipment.

Press the **“Pair”** button to wake the unit up. The green **“Power”** LED will turn on if plugged into the mains.

Pairing

The Connect-iT will be pre-paired to the Companion mini before shipment. These instructions can be used to pair additional Alert-iT radio monitors to the Connect-iT.

To pair the Connect-iT with an Alert-iT radio monitor you can either use the **“Pair”** button on the front of the unit OR connect the unit to a PC via a micro USB cable (Not provided).

Using the **“Pair”** button;

- ✔ Ensure that the required Alert-iT monitor is within 2 meters of the Connect-iT.
- ✔ Using a pen shaped implement, press and hold the **“Pair”** button on the front of the Connect-iT. The **“Monitor”** LED will begin to flash green rapidly.
- ✔ Force the Alert-iT monitor to transmit by **‘tapping’** its reset button or by triggering an alarm.
- ✔ If successful, the **“Monitor”** LED will stop flashing and turn solid green, you can now release the **“Pair”** button.

Clearing the Memory

To clear **ALL** paired monitors from the Connect-iT’s memory, press and hold the **“Pair”** and **“Clear”** buttons together for 8 seconds. All three LED’s will flash together three times as confirmation.

Front panel Lights

The green “**Power**” LED indicates the current power state of the device;

- ✔ **Solid green** = Running on Mains power.
- ✔ **Flashing green every 4 seconds** = Running on battery backup.
- ✔ **Flashing green every second** = Battery backup getting low.

The red “**Alarm**” LED indicates that the wired output has been triggered. Whilst the “**Alarm**” continues to flash red, the wired output will trigger every two minutes.

The “**Monitor**” LED indicates the current state of the paired radio monitors. (See page 17 for more details).

If you have paired the Connect-iT to a Safelink enabled device such as Alert-iT’s EP-iT range, the green “**Monitor**” LED will blink each time the 8 second heartbeat signal is received.

Wired Output

When triggered by a fault or alarm signal, the wired output will activate for 2 seconds then clear. If the alarm remains active, it will re-trigger every 2 minutes until the alarm is cleared.

Resetting an Alarm (Excluding the Companion mini)

Alarms are reset via the paired monitors “**Reset**” button. However, if a paired monitor is no longer accessible (e.g left in an alarm state, then taken off the premises), you can press and hold the “**Clear**” button for 5 seconds to clear any alarm condition on the Connect-iT.

PLEASE NOTE:

For standard use, the alarm must be cancelled at the monitor otherwise the Connect-iT will re-alarm as the monitor will continue to send out alarm signals. However; for telecare, our monitors are typically configured as selfresetting.

For details or concerns on how your system is reset, please contact your telecare or nursecall provider.

Normal Alarms

When a paired monitor sends out an alarm call, the Connect-iT's "**Monitor**" LED will turn solid red. The "**Alarm**" LED will flash every second. The wired output will activate every 2 minutes until the monitors alarm condition has been cleared. See page 16 for resetting an alarm.

Common Fault Conditions

Radio Fail Alarm:

If the Connect-iT has been paired to a device with "**Safelink**" enabled (Type code over 128) it will expect to see the heartbeat signal from the monitor every 8 seconds. If it does not see any heartbeat signals for 2 minutes it will raise a Radio Failure alarm. In this condition the wired output will activate, the "**Monitor**" LED will blink every 2 seconds and the "**Alarm**" LED will blink every 2 seconds.

Monitor Battery Low / Very Low:

When a paired monitors internal battery gets '**low**', the "**Monitor**" led will begin to blink red every second.

When a paired monitors internal battery gets '**very low**', the "**Monitor**" LED will blink every second, the "**Alarm**" LED will start to blink every 2 seconds and the wired output will activate.

Connect-iT Backup Battery Low / Very Low:

When running on the battery backup, the "**Power**" LED will turn from solid green to blinking green every 4 seconds. When the backup battery begins to get low the "**Power**" LED will start to blink every second.

When the backup battery gets '**very low**' the wired output will activate, the "**Monitor**" LED will begin to blink every second and the "**Alarm**" LED will flash.

Mounting the unit to a wall

This Connect-iT is sealed to a IP53 rating (not waterproof) and should be used indoors in a dry area of between 5°C to 35°C and a maximum of 90% Relative Humidity.

The unit should be permanently fitted to a wall near a mains plug and near to the desired nurse call point. A suitable P145 nurse call cable* should be plugged into the wired output and into the desired nurse call point. (The red end of the P145 cable should be plugged into the wired output).

A wall mounting kit has been provided to attach the device to a wall. The back plate is removed by lifting the tab underneath. This is fixed to the wall using the wall mounting kit and the unit is then clipped back onto the plate.

The power and nurse call cable can then be plugged in. Ensure these cables are routed to avoid the risk of trips, entanglement or ligature.

*See page 19 for further information on nurse call cables.

Removing the Connect-iT from Service

If the Nurse Call Receiver is no longer needed and needs to be removed from service, the back plate can be unscrewed from the wall and clipped back onto the unit. The Nurse Call Receiver can then be turned off by press and holding the “**Clear/Wake**” button for 10 seconds. The relay will activate for 2 seconds upon shutdown.

The backup batteries should still be tested when returning the unit to service to ensure the battery backup performs as desired. See page 24 for details.

Please ensure only rechargeable batteries are used;
Batteries: 2x AA Ni-MH (HR6) Re-chargeable 2500mAh.

Leads available from Alert-iT

Our wide selection of nurse call leads has grown over many years so it is very likely that we will already have a suitable lead available to connect the Nurse Call Receiver to your nurse call system.

Please browse our website or contact our sales team to help you find the correct lead;

Call: +44 (0) 1530 239 900

Email: sales@alert-it.co.uk

Visit: www.alert-it.co.uk/product-category/accessories/

If we don't currently have one suitable for you, please send us your connection details and we will add it to our catalogue for you.

Wired Output Specification

If you wish to make your own lead, the connection into the Connect-iT can be wired as follows:

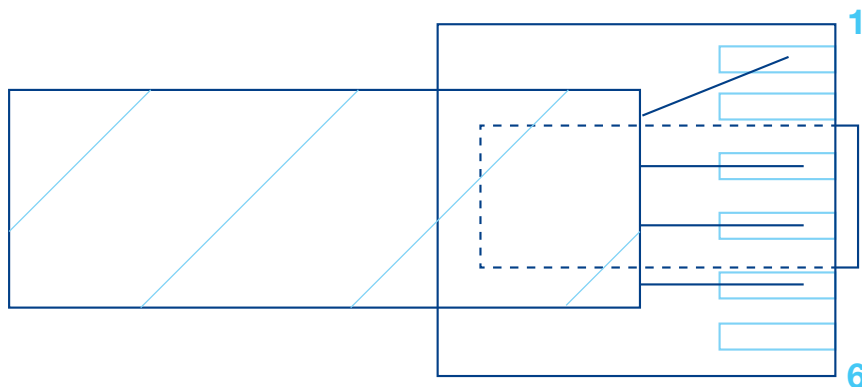

- PIN 1** Normally Closed
- PIN 2** 12V Out
- PIN 3** Normally Open
- PIN 4** Common
- PIN 5** 0v
- PIN 6** No Connection

Connector: RJ11 / RJ12 (Gold contacts visible on top, clip underneath)

There are some additional configuration options that can be changed using the Alert-iT Profile Editor. Once the device has been connected to a computer running the software (Available via our website) using a micro-USB cable (not provided), the following options can be changed;

Latched Relay Output [Default = Disabled]. The wired output is pulsed for 2 seconds every 2 minutes by default, enabling this option latches the relay permanently until the alarm is cleared. Note: This will significantly reduce the backup battery life if the wired output is left active for long periods of time and the mains power is off.

Fault Code Warnings [Default = Enabled]. By default all fault codes received from paired monitors will trigger the wired output. Disabling this feature will mean fault codes do not trigger the wired output. It is not recommended to disable this feature.

Sounds [Default = Enabled]. There is an internal piezo sounder that will alert the user to various fault conditions.

Hidden Lights [Default = Disabled]. The LED's on the front of the unit can be unwanted by users, especially at night if the unit is fitted in a bedroom. Enabling this option will hide the LED's after 1 minute. Briefly pressing the "Wake/Clear" button on the bottom of the unit will wake up the LED's for 1 minute.

A "Discreet Mode" can be activated by holding the "Wake/Clear" button on power up. To do this, unplug the mains adapter and remove one of the batteries. Press and hold the "Wake/Clear" button, insert the battery, then release the button. All the LED's will now be hidden until the "Wake" button is tapped again, at which point the LED's will then 'wake-up' for 1 minute. In this mode sounds are also disabled. To revert to defaults, unplug the power jack, then remove and reinsert the batteries.

Alternatively for repeat orders or regular customers please let us know if you would like any of these features enabled and we can configure the unit for you before shipment.

Routine Testing of the Backup Battery

After each year in service the backup battery should be checked by simulating a power cut.

This can be done by turning the plug off at the socket / un-plugging the 3-pin plug from the wall / or pulling the 12v DC jack out of the Connect-iT.

You should then ensure the unit keeps functioning for a reasonable period (e.g. 24 hours), by observing the “**Power**” LED and the activation of the wired nursecall output/Radio system when any alarm calls are raised. If the “**Power**” LED is not flashing and Alarm Calls fail to activate after 24 hours, replace the batteries.

To replace the battery, unclip the unit from the wall using the tab underneath. The rear case will stay fixed to the wall and the 2 batteries will be exposed on the back of the unit.

You must only use rechargeable batteries; 2 x AA Ni-MH (HR6) Re-chargeable 2500mAh.

How to Clean the Device

The unit can be cleaned by wiping the unit with cotton wool pads moistened (compressed until dripping stops) with a mild detergent (0.5% washing up liquid) solution or by using an alcohol or baby wipe. Avoid getting any liquid into the micro-USB connector, output connector or power socket.

Third Party Radio Transmitters

There is a 3-pin header available inside the Connect-iT that can be connected to third party radio transmitter modules. This can be used by third parties wishing to integrate Alert-iT radio products with their radio systems.

The 3-pin header provides 3v power and has an enable pin that is activated whenever the wired output is activated. This means that when the Connect-iT is activated by an alarm call from a paired Alert-iT Radio monitor the enable pin is activated, triggering the third party radio module which then triggers the third party radio system.

Third party radio modules currently available directly from Alert-iT include;

- ✔ Telealarm (Bosch), Tyntec, Tunstall, Tunstall EU.
- ✔ For Appelo, DoroCare (Caretec), Possum and Tyntec please contact these suppliers directly.
- ✔ If your radio system is not listed please contact us to advise suitability.

	Power LED	Monitor LED	Alarm LED	Output
Normal (Powered by Mains Power)	Solid Green	Off or blinking Green every 8 seconds if paired to a Safelink enabled monitor	Off	Off
Mains Power off and running on Backup Battery	Blink every 4 seconds	—	Off	Off
Backup Battery Low	Blinking every second	—	Off	Off
Backup Battery Very Low	Blinking every second	—	Blink every 2 seconds	Active
Monitor in Alarm	—	Solid Red	Blink every 2 seconds	Active
Monitor Battery Low	—	Blink Red every second	Off	Off
Monitor in other Fault. e.g. Battery Very Low	—	Blink Red every second	Blink every 2 seconds	Active
Radio Fail (Monitor out of range / turned off)	—	Blink Red every 2 seconds	Blink every 2 seconds	Active

For 3 years from the date of purchase of the initial equipment, Alert-iT will offer you;

- ✔ Access to support between the hours of 9.00am and 5.00pm each weekday (excluding Public Holidays) via the telephone help-line for the purposes of fault diagnosis and the provision of advice.
- ✔ Repair (or if this is not possible-replacement) of faulty equipment free of charge, however, the equipment must be returned to Alert-iT at your own expense.
- ✔ After inspection by Alert-iT engineers, any equipment that is deemed to have been damaged, rather than failing due to a technical fault will only be repaired after you have agreed to being invoiced for the cost of repairs and delivery.
- ✔ This agreement will terminate 3 years after the initial date of purchase, regardless of any new equipment being issued in the interim period.

Please note that liquid ingress voids warranty.

NOTE:

For those requiring support outside of Alert-iT's office hours, please contact our sales team and ask about our Premium support packages.

Companion mini Specification

Connections:	B-Micro USB 2.0
Weight:	54g
Material:	White ABS Anti-microbial
Dimensions (mm):	100 x 45 x 15 (HxWxD)
Batteries:	2x AAA (LR03) Non-rechargeable
Battery Life:	12 months
Operating Temp:	5°C to 35°C (Used Indoors)
Humidity:	90% max. Non-condensing
Sealing:	IP53 (not waterproof)

Certification

The product complies with 93/42/EEC as a Class 1 Medical Device for use in a Home Healthcare environment.

Hereby, Alert-iT Care Alarms declares that this product is in compliance with the Radio Equipment Directive (2014/53/EU). The product contains a radio transmitter compliant to EN 300-220-2 operating at 434.075 MHz wideband, 10mW power (Class 8) less than 1% duty cycle (Class 2). The full text of the EU declaration of conformity is available at the following internet address;

www.alert-it.co.uk/support-area/

The system complies with EN 60601 for Class 2 Electrical Safety and does not need a protective earth and Group 1 Class B for EMC in a Home Healthcare environment.



PLEASE NOTE:

None of the components, including batteries should be disposed of as Domestic Waste.

For information on disposal contact Alert-iT.

Connect-iT Specification

Power:	2.1mm 12V DC
Weight:	164g
Material:	White ABS Anti-microbial
Dimensions (mm):	90 x 90 x 31 (HxWxD)
Batteries:	2x AA (HR6) Ni-MH Rechargeable 2500mAh
Battery Backup:	>24 hours*
Charging time:	12 hours
Operating Temp:	5°C to 35°C (Used Indoors)
Humidity:	90% max. Non-condensing
Sealing:	IP53 (not waterproof)
Radio Range:	Up to 200 meters

*NOTE:

The backup batteries performance will degrade over time, routine testing must be performed to ensure the backup batteries performance has not degraded beyond acceptable levels. See the “Maintenance Instructions” section for further details.

Certification

Hereby, Alert-iT Care Alarms declares that this product is in compliance with the Radio Equipment Directive (2014/53/EU). The system has a radio receiver compliant to EN 300-220-2 ‘Class 2’ operating at 434.075 MHz wideband. The full text of the EU declaration of conformity is available at the following internet address;

www.alert-it.co.uk/support-area/

The system complies with EN 60601 for Class 2 Electrical Safety and does not need a protective earth and Group 1 Class B for EMC in a Home Healthcare environment.



PLEASE NOTE:

None of the components, including batteries should be disposed of as Domestic Waste.

For information on disposal contact Alert-iT.

Serial Number: _____

Test	Signature	Date
1		
2		
3		
4		
5		
6		
7		
8		
9		
10		
11		
12		
13		
14		
15		
16		
17		
18		
19		
20		

Serial Number: _____

Test	Signature	Date
1		
2		
3		
4		
5		
6		
7		
8		
9		
10		
11		
12		
13		
14		
15		
16		
17		
18		
19		
20		

Changing settings on the Companion Mini

All the Companion Mini's are supplied with a default setting;

- ✓ Medium sensitivity (2)
- ✓ 15 Seconds delay (The Companion Mini with detects 15 seconds of continuous movement before alarming).

If required, these setting can be adjusted using the Alert-iT profile Editing software which is available to down load free from our Support page www.alert-it.co.uk/support

Installation instructions are available with in the download.

A USB lead is provided to connect between the Mini and your Computer.



Using Profile editor

Place the Companion Mini in to test mode (see device installation section on this handbook)



Click on the Icon which should be found on your desktop after Profile editor has been installed.

Click on seizure detection settings to make adjustments.

Click save the device to save new settings.





This symbol indicates there are warnings and precautions associated with the use of this equipment. This instruction manual should be carefully read and understood before using the equipment.

1. Ensure the voltage & current rating of remote signalling equipment (Nurse Call etc) does not exceed the maximum allowed (50v/100mA)
2. Ensure that the nurse call lead and power cables are routed and secured to avoid the risk of trips, entanglement or strangulation.
3. Regularly check the power supplies for damage and potential shock risks.
4. Ensure, by testing, that the alarm is annunciated at the carer's location(s).
5. Clean and disinfect each item regularly in accordance with information on page 15.
6. Regularly test device as defined herein.
7. Use only the power supply and batteries recommended.
8. Operate power supply away from direct heat and uncovered.
9. As with all electronic equipment there is potential for the equipment to interfere with or be effected by interference from other electrical or electronic devices. For this reason avoid placing the monitor, sensor or connecting cable in close proximity to sensitive electronic devices or devices which produce strong electromagnetic fields such as radio transmitters, mobile phones or power cables.
10. Only use the monitor with accessories approved for use with this product and only in accordance with instructions.
11. If the equipment is modified in any way, appropriate inspection and testing must be conducted to ensure continue safe use of the equipment.
12. The carer must conduct a risk assessment to determine if the level of reliability offered by the monitor is sufficient or if additional monitoring is needed. Contact the manufacturer for assistance with Risk Evaluation Tools. Consideration on the users likelihood to tamper with the system must be included.
13. Additional levels of mechanical protection may be needed for some disorders. Contact the manufacturers for advice.
14. The carer must never clear an alarm without checking the user's condition.
15. Some accessories are fitted with small screws and have plastic bags. Ensure these do not come into the possession of vulnerable people who might choke on them.

The Alert-it system has been designed with due regard to reliability and integrity. While it offers a highly vigilant monitoring method, it is always possible that a distress condition can go undetected for a variety of reasons (including malfunction) and in life threatening situations it is advisable to use the Alert-it system in conjunction with additional monitoring techniques (e.g. video). Neither the manufacturer nor its agent can accept legal responsibility to provide a system that is infallible. The carer is responsible for assessing the risks of using this equipment and any settings pertaining to it.



Address:

Alert-iT Care Alarms
Fernie House, Unit 3
Jackson Street
Coalville Business Park
Leicester. LE67 3NR

Call:

+44 (0) 1530 239 900

Visit:

www.alert-it.co.uk

Social:

 AlertitCareAlarms

 Alert_iT_Care

 Alert-iT

UH1479A v4



LESS STRESS CARING